



# ADS

automatic disc scraper filter

[www.auxill.nl](http://www.auxill.nl)

## ADS Filters



The ADS Filter is a self cleaning filter which filters solids out of fluid. The available filter materials are perforated plate, wedge wire element or our new alternative: sintered metal.

### Applications

#### Chemical industry

- ammonia
- solvents
- softening agents
- glycols
- adhesives
- chemical base materials
- suspensions
- lye's
- waste liquids etc.
- washing liquids
- distillation and reaction fluids
- surfactants
- for preliminary and coarse filtering
- upstream of distillation columns
- reactors, flue gas scrubbers
- pumps
- fine filter
- filling plants

#### Paint and color industry

- varnishes
- dispersions
- coatings
- tar products
- agents

#### Beverage industry

- wineries (must filtration)
- breweries
- distilleries

#### Cosmetic industry

- soaps
- fats
- essences
- tooth pastes

#### Car industry & metalworking

- degreasing baths
- cooling liquids
- lubrication liquids
- greases
- cooling water
- washing and scrubbing water
- process water
- water from cutting processes

#### Mineral oil industry

- oils
- greases
- solvents
- waste oils
- diesel oils
- lubricating oils
- heating oils
- heat transfer fluids
- reclaimed oils
- salt water
- lime processes

#### Plastic industry

- base products
- PVC- and PU-pastes
- rubber products
- silicones

#### Food industry

- sweets
- dairy products
- fats
- flavors
- concentrates
- treacle's

Plus many other applications in the electro, optic, pulp & paper, leather and sugar industry.

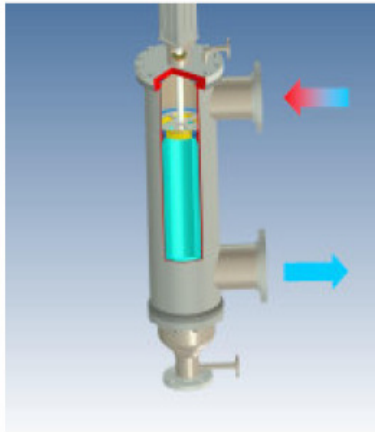

The fluid or suspension enters through the inlet at the top of the ADS Filter, flows freely through the opening of the scraper and is filtered at the wedge wire element, perforated plate of sintered metal. The flow runs from the inside out.

Solid larger than the filter fineness of the filter element will be stopped.

The filtered fluid flows through the outlet to a lower part of the filter.

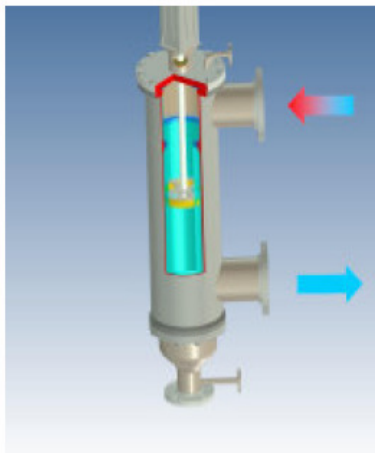

The collected particles will be removed from the inside of the surface manually, by timer or by  $\Delta P$  steered by a pneumatic driven scraper.

This will result in an instantly clean filter surface with limited pressure drop of the filter element.

Even with minimal fluid loss it is not always necessary to purge the solids collecting chamber. By cleansing of the screen a higher frequency is required than by purging the collecting chamber.

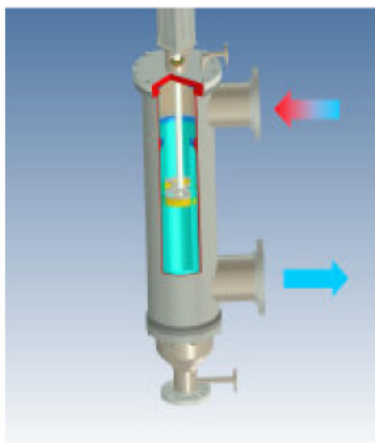

The continuous flow of the product prevents the particles to come back up through pressure in the collecting chamber below, as physically prescribed. Solids will pile up in the chamber, ready for removal by the activated bottom mounted purge valve.

This can be done manually or automatically, depending on the degree of automation.

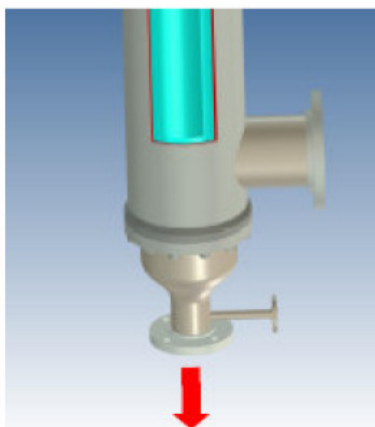

At preset intervals the collected solids are purged, either manually or automatically, directly through a purge valve or through the under the two stage purge system mounted filter housing. This results in a minimum liquid loss. This is not always possible, for example, with sticky solids.

The purging can be carried out without interrupting the filtration process.

## Features

- Filters from 0,5  $\mu$  to 3 mm available
- Minimum material quality is SS 316L
- Maximum temperature up to 50 °C or more (optional)
- High differential pressure up to 5 bar
- Inside - outside filtration
- No product contamination
- Purging by pinch- or butterfly valves
- Taylor made execution possible
- ATEX proof because of complete pneumatic system
- Self cleaning
- Easy installation
- Remote controllable.

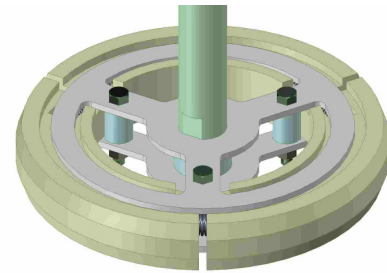

Fig. Schrapper

## Benefits

- No cartridge use
- No waste or disposal of filter cartridges
- Minimal product loss during purging
- No interruption of production process
- Easy to dismount and inspect
- May be used for all kinds of liquid
- Low operating costs
- Solidly built filter housing
- Limited maintenance, uncomplicated and reliable design
- Filtration level 0,5  $\mu$  - 3 mm
- Continuous cleaning of the filter surface ensures minimum pressure drop
- The use of different construction materials and equipment facilitates makes application possible in any field of industry
- Large flow possible by using manifolds, or bigger filter housings including more elements.

### Specifications ADS 2075 (ADS 20100 = optional)

Measurement	See drawing next page
Design pressure	16 bar, higher is optional
Test pressure	24 bar
Design temperature	50°C, higher is optional
Tank volume	0,08 m <sup>3</sup>
Weight	165 kg
In- en uilet	DN 150 PN 16
Purge uilet	DN 65 PN 16
Air uilet	DN 25 PN 16
Rinse water connection	DN 25 PN 16
Measurement filter element	D = 200 mm L = 750 mm (L = 1.000 mm is optional)

## General measurements and significant services type ADS 2075

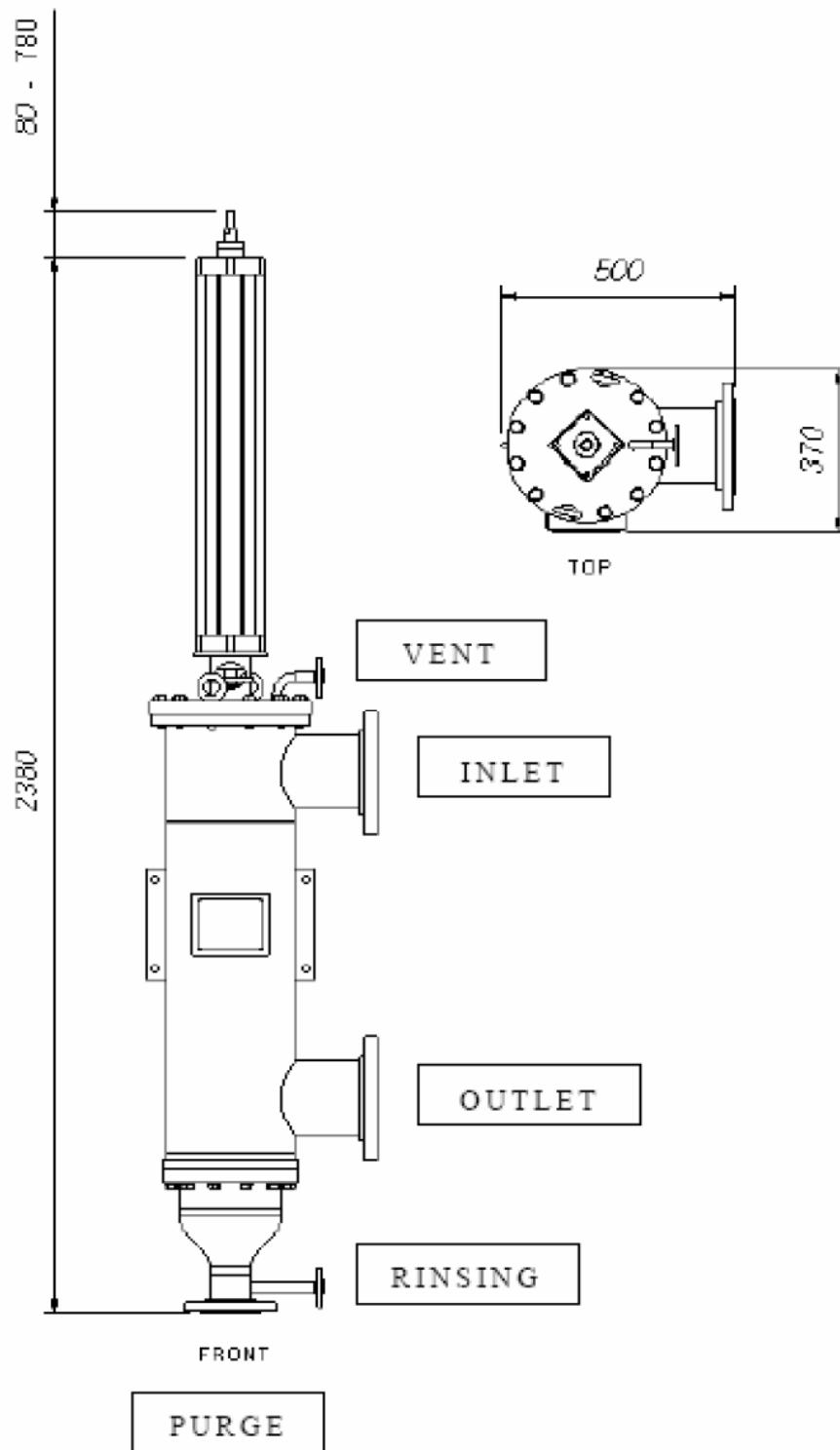

## ADS Filter of sintered metal

Sintered metal is a new type of filter material used in the ADS Filter. It is made of pressed metal powder, for example, SS, titanium, hastelloy or monel. It has a filter fineness range between 0,5 - 200  $\mu$ . Where ever filter media or flocculants were used with a filter fineness of < 15  $\mu$ , we now have a ecofriendly alternative.

### Advantages ADS Filter of sintered metal

- No need of filter media or flocculants
- Low power use
- Sustainable
- Self cleaning
- Low maintenance
- Easy to use
- No process interruption
- Able to work with large flows.



### Manufacturing the sintered metal element

All ingot metallurgical materials can be produced as powder. Shape, size and distribution of the powder particles are important parameters high effect the properties of high porosity sintered components. Besides permeability, grade efficiency and mechanical strength, the corrosion resistance often is of prime importance for the field application. Sintered elements are manufactured in a wide variety of materials depending on the requirement. The most popular materials are stainless steel alloys as well as titanium, monel, inconel, hastelloy and other special materials.

Filter elements of sintered metal are produced by cold isostatic pressing. For the compaction process the metal powder is filled into the compacting tool which is made of a solid steel core and oversized outer rubber sleeve. By sealing this assembly and immersing it in a liquid inside a vessel that then is pressurized, a pressed part will be obtained. Most importantly, this part will have uniform porosity with homogeneous, physical characteristics and properties over the total part.

This processing method allows the manufacture of seamless filter elements up to 1500 mm length and 320 mm diameter with various wall thickness. This isostatic pressing process also allows flanged or threaded end pieces to be simultaneously attached when the filter is formed. Welds thereby are eliminated and the mounting of such filter cartridges and filter tubes in the filter apparatus is very much simplified. An advantage of the isostatic technique compared to other manufacturing technologies is that smaller quantities also can be economically produced.

### Sintering

The compared part is removed and then sintered in specially designed furnaces. Sintering is the fundamental processing step for the Powdered Metal (P/M) products. It is the process of bonding the powder particles by fusing together at temperatures well below their melting point.

After sintering, regardless of micron size, the separate grain structure of the original powdered metal becomes fully interlinked to form a rigid part. Sintering gives the high porosity material the shape, stability and property of a strong metal component. Filters of sintered metal are used as self-supporting structural elements. The pores after the sintering process are mechanically fixed with respect to both size and position.

### Properties

These characteristics result in the following important properties of these filters:

- Shape-stability, i.e. self-supporting structural elements suitable for high differential pressures and pressure swings
- Particularly good properties under compression, vibration and changing conditions or with high impulse pressures
- High heat resistance and thermal stability up to 950 °C
- High permeability with low pressure drop
- Precise filtration because of homogeneous pore size distribution
- Chemical resistance against acids and caustic solutions in various ranges of pH
- Back flushing and easy cleaning with supersaturated superheated steam, chemical solvents, thermal processes and ultrasonically
- The variety of materials used are weldable, solderable and machinable.

### Applications

Filters of sintered metal are employed in:

- Catalyst separation and recovery
  - Refinery applications
  - Gas and liquid filtration
  - Aerosol separation
  - Sparging
  - Fluidization
  - Air bearings for polymer sheet production
  - Silencing
- as well as other fields of chemical and food processing industries, power engineering and environmental technology.

### Properties of sintered metal

Filter grade	Filterfinesness (μ)
ADS sintering 0,5	0,6
ADS sintering 1	1
ADS sintering 3	3
ADS sintering 5	5,8
ADS sintering 8	9,2
ADS sintering 10	10
ADS sintering 15	18
ADS sintering 20	24
ADS sintering 30	35
ADS sintering 50	45
ADS sintering 80	60
ADS sintering 100	98
ADS sintering 150	135
ADS sintering 200	173

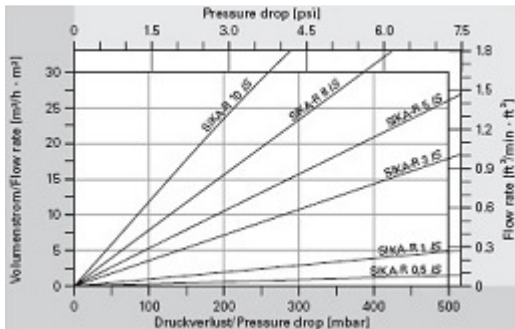

### Mean value characteristic lines of the permeability of water in metal membranes

Characteristics lines established in accordance with DIN ISO 4022

Medium: water

Filter thickness total:  $s = 3\text{mm}$

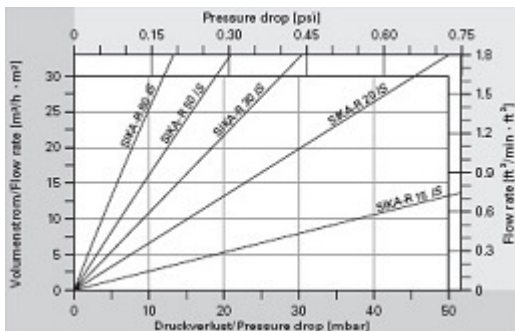

### Mean value characteristic lines of the permeability of water in Stainless Steel filters

Characteristic lines established in accordance with DIN ISO 4022

Conditions

Geometry: wall thickness,  $S = 0.12\text{ inch}$

Filter surface:  $A = 8.6\text{ sqi}$

Water temperature:  $T = 8\text{ °C}$

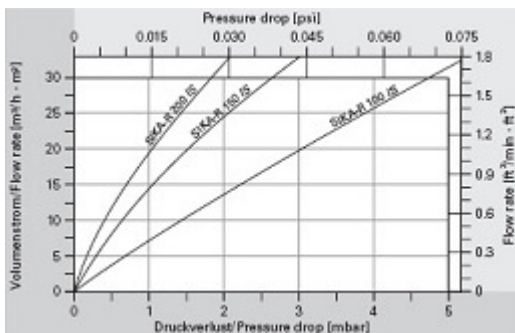



## Other screen options type ADS or ADS 201000

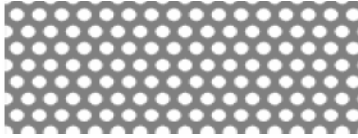

### Perforated plate

Screen size	Free surface	Standard material	Option
400 μ	9,0 %	SS 304	SS 316 L
500 μ	14,5 %	SS 304	SS 316 L
600 μ	32,5 %	SS 304	SS 316 L
750 μ	23,0 %	SS 304	SS 316 L
800 μ	26,0 %	SS 304	SS 316 L
1.0 mm	40,0 %	SS 316 L	-
1,2 mm	26,0 %	SS 304	SS 316 L
1,25 mm	23,0 %	SS 304	SS 316 L
1,5 mm	33,0 %	SS 316 L	-
2,0 mm	40,0 %	SS 316 L	-
2,5 mm	35,0 %	SS 304	SS 316 L
3,0 mm	33,0 %	SS 316 L	-



### Wedge wire element

Screen size nominal	Free surface	Standard material	Option
35 μ	3,4 %	SS 316 L	-
50 μ	4,7 %	SS 316 L	-
75 μ	6,9 %	SS 316 L	-
100 μ	9,1 %	SS 316 L	-
150 μ	14,6 %	SS 316 L	-
200 μ	16,7 %	SS 316 L	-
300 μ	23,1 %	SS 316 L	-
500 μ	33,3 %	SS 316 L	-



Meester Lovinklaan 18 • 7004 BJ • Doetinchem  
telefoon: +31.314.391706 • fax +31.314.391748 • [info@auxill.nl](mailto:info@auxill.nl) • [www.auxill.nl](http://www.auxill.nl)